

Design of the New NY (Tappan Zee) Bridge Cable-Stayed Main Span

Christopher Scollard, P.Eng., Project Manager, Buckland & Taylor Ltd.
Don Bergman, P.Eng., P.E., Vice President, Buckland & Taylor Ltd.
Armin Schemman, P.Eng., Design Manager, Buckland & Taylor Ltd.
Matthew Kleymann, EIT, Design Lead, Buckland & Taylor Ltd.
Tjen Tjhin, P.Eng., P.E., Design Lead, Buckland & Taylor Ltd.

Paper prepared for presentation
at the **Structures** Session

Of the 2014 Conference of the
Transportation Association of Canada
Montreal, Quebec

Abstract

The existing Tappan Zee Bridge crosses the Hudson River approximately 25 miles (40 km) upstream of New York City, connecting the communities of South Nyack and Tarrytown, and was constructed in 1955. The bridge is functionally obsolete, carrying far more traffic than it was designed for, the timber pile foundations are deteriorating and maintenance and rehabilitation costs were estimated at \$3 to \$4 billion over the next 20 years, with \$750 million having already been spent over the past 10 years.

The New NY (Tappan Zee) Bridge Project includes the demolition of the existing bridge and replacement with separated east and west bound structures. The New NY Bridge is an important investment and critical asset for the New York State Thruway Authority (NYSTA) and all of the bridge's daily users. The bridge is designed for a 100-year service life before major maintenance for non-replaceable components using a limit states design approach that is new to North America. Components that can be replaced without significant disruptions to bridge use are designed for lower service lives.

The new main span comprises parallel east and west bound cable-stayed bridges with 1,200' (366 m) main spans and 515' (157 m) side spans. The main span bridges comprise composite steel and concrete decks, parallel strand stay cables, iconic V-shaped reinforced concrete towers, reinforced concrete anchor piers and pile caps, and reinforced concrete-filled steel pipe pile foundations. The foundations and pile caps are designed to support the future installation of a cable-stayed commuter rail bridge between the adjacent east and west bound road bridges. The road bridge towers are designed to be expanded and strengthened in the future to support the rail bridge superstructure.

Similar to the importance placed on service life design, the provision of redundancy in the New NY Bridge was a strong guiding principle. The bridge includes several features that address operational and structural redundancy. Operational redundancy refers to the flexibility available to the bridge operator to adjust how traffic is conveyed across the bridge. Structural redundancy refers to the ability of the bridge to sustain localized damage/failure without it leading to progressive collapse.

This paper describes the design of the main span bridges and the features of the design that will allow the bridge to achieve the stringent service life requirements and remain safe and serviceable for all required loading and operational scenarios.

Introduction

The existing Tappan Zee Bridge crosses the Hudson River approximately 25 miles (40 km) upstream of New York City, connecting the communities of South Nyack and Tarrytown. The bridge is approximately 3 miles (4.8 km) long and comprises composite steel plate girder and deck truss approaches and a 369 m long steel cantilever truss main span. The bridge is supported on steel and concrete piers and foundations comprise timber piles and floating caissons for the main piers. The bridge carries seven traffic lanes, with the central lane alternating direction for morning and evening rush-hours. The bridge was constructed in 1955 by American Bridge Company. The existing bridge is functionally obsolete, carrying far more traffic than it was designed for, the timber pile foundations are deteriorating and maintenance and rehabilitation costs were estimated at \$3 to \$4 billion over the next 20 years, with \$750 million having already been spent over the past 10 years.

The New NY (Tappan Zee) Bridge Project includes the demolition of the existing bridge and replacement with separated east and west bound structures supported on common foundations. The project also includes design for potential future rail loading on structure that will be located between the new east and west bound roadways. The east bound bridge carries four 12' (3.66 m) wide traffic lanes and is 87' (26.64 m) wide and the west bound bridge carries four 12' (3.66 m) wide traffic lanes and a 12' (3.66 m) wide shared use path and is 96' (29.28 m) wide. Both bridges provide wide inner and outer shoulders.

The new main span comprises parallel east and west bound cable-stayed bridges with 1,200' (366 m) main spans and 515' (157 m) side spans, as shown in Figure 1. The main span bridges comprise composite steel and concrete decks, parallel strand stay cables, iconic V-shaped reinforced concrete towers, reinforced concrete anchor piers and pile caps, and reinforced concrete-filled steel pipe pile foundations.

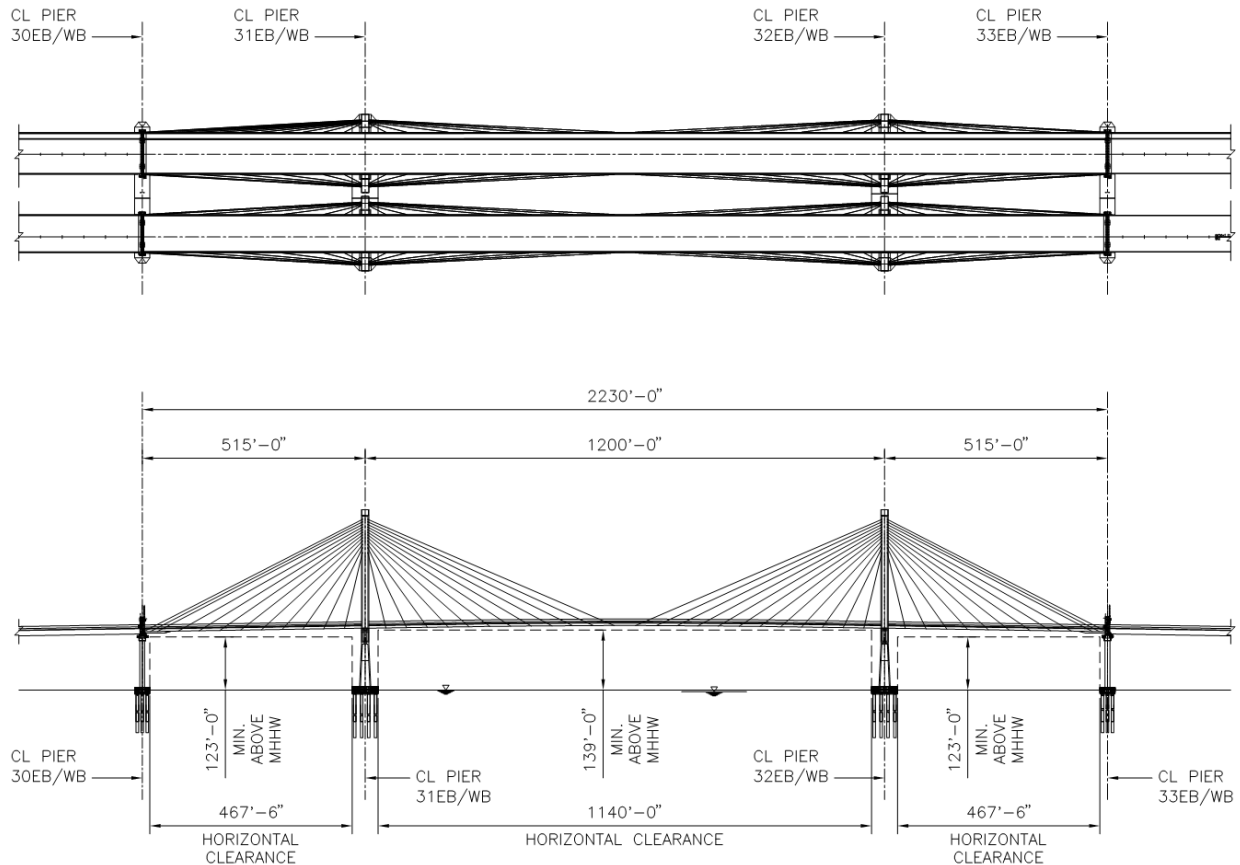

Figure 1: Main span plan (west bound top, east bound bottom) and elevation views.

The bridge is designed for a 100-year service life before major maintenance for non-replaceable components using probabilistic assessment methods new to the North American market.

The foundations and pile caps are designed to support the future installation of a cable-stayed commuter rail bridge between the adjacent east and west bound road bridges. The road bridge towers are designed to be expanded and strengthened in the future to support the rail bridge superstructure.

This paper describes the following aspects of the main span design:

- Service Life Design
- Articulation
- Foundations
- Substructures
- Superstructure
- Future Rail Bridge

Service Life Design

General

Service life design refers to the comprehensive integration of the structural design, durability design, structural health monitoring system design and planning for the future operations – access, inspection and maintenance of the bridge in service.

The New NY Bridge is an important investment and critical asset for the New York State Thruway Authority (NYSTA) and all of the bridge's daily users.

Recognizing that service life is much more economically achieved through proper consideration in the original design and construction than with later rehabilitation, the bridge is designed for a 100-year service life before major maintenance for non-replaceable components. Components that can be replaced without significant disruptions to bridge use are designed for lower service lives.

Durability Design

The durability design is based on the classification of each bridge component by its environmental exposure zone. Exposure zones include: embedded (in the ground), submerged (permanently below water), splash/spray, atmospheric and de-icing salt spray. Corrosion protection strategies are tailored to each combination of component and exposure. An example of the discretization of the main span towers into its exposure zones is shown in Figure 2. The piles are embedded into the ground and permanently submerged in the river; the pile caps and lower portions of the tower lens are subjected to splash and spray from the brackish river water; the cross beams and portions of the tower legs well above and below the deck are exposed only to the atmosphere; the tower legs adjacent to the bridge deck are exposed to the de-icing salt laden road spray.

Concrete Components

Probabilistic service life assessments for concrete structures are based on fib (International Concrete Federation) Bulletin 34 "Model Code for Service Life Design". The Model Code allows the durability design to be based on either of two strategies: i) Avoidance of deterioration by the use of non-reactive materials (e.g., stainless steel reinforcement); or ii) Full probabilistic assessment, for deterioration mechanisms that cannot practically be avoided.

The full probabilistic approach is used to assess chloride-induced reinforcement corrosion which is the deterioration mechanism controlling the required concrete cover and permeability on this bridge. The full probabilistic approach treats durability design like structural design in that it is based on limit states design theory. It characterizes durability loads (surface chloride concentration, temperature etc.) and durability resistances (concrete permeability, concrete cover etc.) as random variables with mean values, coefficients of variation and distribution types. The corresponding limit state is defined as the chloride ion concentration at the level of the steel reinforcement being larger than the threshold beyond which corrosion can occur (referred to as depassivation).

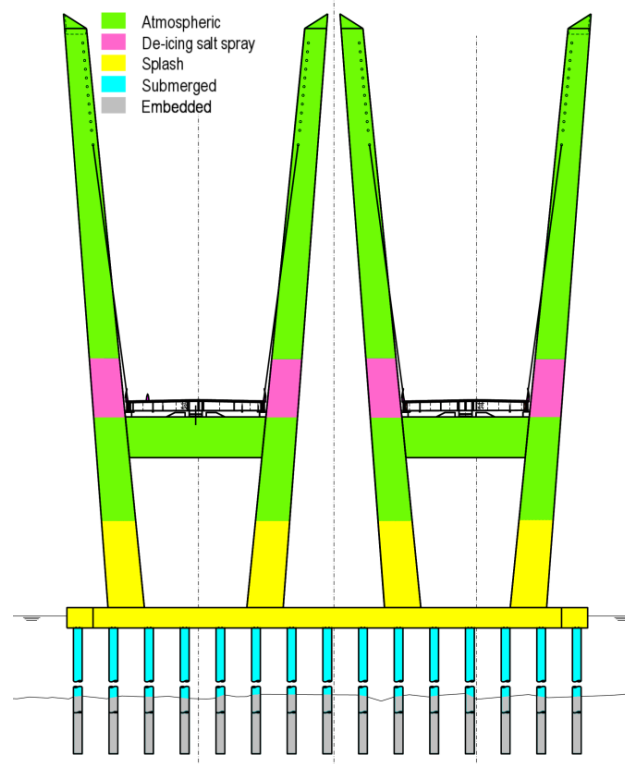

Figure 2: Tower exposure zones.

Probabilistic analysis is conducted using the second order reliability method to identify the concrete permeability (represented by the maximum chloride migration coefficient) and cover thickness necessary to prevent depassivation of the reinforcement during the required service life, with a defined certainty. The reinforcement corrosion limit state is evaluated based on a target reliability index of 1.3, corresponding to a 10% probability of occurrence during the required service life. This reliability index is lower than that considered for strength design, but this is appropriate because the consequences of the limit state occurring are minor rather than catastrophic. For the New NY Bridge, all reinforcement is galvanized and concrete covers vary between 1.5" and 4" (38 mm and 100 mm), depending on exposure zone, as per standard State practice. In this case the probabilistic assessments are used primarily to determine the maximum chloride migration coefficients required for various cementitious material combinations that might be used by the Contractor.

Other Components

The durability design of non-concrete components considers each component's exposure, function, criticality and vulnerability. Criticality is defined as the risk of a durability-related failure within the required service life and is determined using the matrix in Table 1. The risk is the notional product of the failure consequences and the failure probability. Consequences of failure are measured in terms of safety, life-cycle costs and restrictions on bridge use. Vulnerability is the notional product of the component criticality

and the expected time to failure (i.e. how likely is it that critical deterioration is observed before failure?) and is determined using the matrix in Table 2. The service life design is developed such that as-designed components (including necessary corrosion protection strategies and proposed inspection and maintenance regimes) are not highly critical or highly vulnerable.

Table 1: Criticality matrix.

Probability	Consequence		
	Low	Moderate	High
Unlikely	Low	Low	Low
Possible	Low	Medium	High
Likely	Medium	High	High

Table 2: Vulnerability matrix.

Time to Failure	Criticality		
	Low	Medium	High
Short	Low	High	High
Medium	Low	Medium	High
Long	Low	Low	Low

Considering these reliability-based assessments, weathering steel with a durable three-coat paint system will be used for the main structural steel components. The intent of the painted weathering steel is to provide two nested layers of corrosion protection, such that the steel's inherent corrosion resistance is only required after the failure of the initial application of the paint system, making touch-ups and complete recoating less urgent than if non-corrosion resistant steel was used. Miscellaneous steel components are galvanized or metallized and anchors and other attachments are galvanized or stainless steel, depending on exposure zone. Non-replaceable components that cannot be readily inspected or maintained, such as the steel pipe piles, are designed with a corrosion loss allowance appropriate for their environment. For the steel pipe piles the loss considered in the design is 3/8" (10 mm) in the submerged zone and 1/8" (3 mm) in the embedded zone.

Structural Health Monitoring System

The bridge is equipped with a structural health monitoring system that allows the remote monitoring and analysis of bridge behaviour. The system continuously records specific aspects of the bridge behaviour and can alert the bridge operator to extreme events, provide insight into the type of event (earthquake, extreme wind, vessel collision etc.), identify design thresholds that might have been exceeded and help to most appropriately direct post-event inspections. The system comprises weather stations, deck temperature sensors, GPS receivers for monitoring bridge movements, settlement gauges, strain gauges, accelerometers, corrosion sensors, tilt meters, weigh-in-motion sensors and transducers to measure expansion joint/bearing movements and rotations.

Access

The voids inside the tower legs are accessible via doors/hatches at deck level, at the tower tops, and also at pile cap level for the interior legs only. The tower cross beam can also be accessed through a hatch in the cross beam top flange and through a passageways to the tower legs. Each tower leg is provided with an elevator and access platforms and ladders over their full height. Tower and anchor pier exteriors are provided with stainless steel anchors to facilitate rope access for inspection and maintenance. The anchor pier cap beam can be accessed from the bridge deck via ladders mounted to the overhead sign structure or via the under deck catwalk on the approach span or main span.

Below deck superstructure access is provided by a fixed catwalk that runs from anchor pier to anchor pier connecting to the approach span catwalks. The catwalk is contained within the superstructure depth, typically passing through cut-outs in the floorbeam webs, except at the towers, where continuity is

provided via the top of the cross beam, and at the anchor piers, where the continuity with the approach span catwalk is provided via platforms that traverse the cap beam perimeter. The underside of the main span deck is also accessed by four travellers (two per main span and one in each side span). Each traveller provides access to the full bridge width and each fascia, and is equipped with an elevating platform that can traverse the traveller width and provide hands-on access to the underside of the concrete deck. The travellers are suspended from galvanized steel rails attached to the floorbeams.

The anchor pier and tower pile caps provide mooring cleats to facilitate boat access to the main.

Articulation

The main span superstructures are connected longitudinally to each tower by four hydraulic lock-up devices (LUDs) and to the anchor piers by longitudinally fixed bearings. The LUDs restrain rapidly applied loads, such as seismic and dynamic wind, distributing loads equally to the two towers. The LUDs provide minimal restraint to slowly applied loads, such as static wind, temperature change and creep and shrinkage of the concrete deck, preventing the accumulation of forces in the towers and deck due to these effects. Longitudinal movements at the bridge ends are accommodated by flexing of the anchor piers. The use of fixed bearings simplifies the design, construction and maintenance of the anchor pier tie-down components in comparison to that required for tie-downs that would accept sliding bearings. Fully sealed modular expansion joints accommodate relative longitudinal and transverse movements between the main span and adjacent approach spans.

Each tie-down includes four individual cables comprising 0.62" (15.7 mm) diameter weldless low-relaxation strands conforming to the requirements of ASTM A416, Grade 270 (1860 MPa). The tie-downs are post-tensioned so that the longitudinally fixed edge girder bearings are not subjected to uplift for any limit state. Given their importance to the behaviour of the bridge, the tie-downs are protected by five layers of corrosion protection as shown in the cross section through the end floorbeam, tie down anchorage and anchor pier cap beam in Figure 3:

1. Fully sealed modular expansion joint;
2. Steel shield that would prevent run-off leaking through the joint from contacting the cable or the anchorages;
3. Flexible neoprene boot encapsulating the tie-down strands fastened to the upper and lower guide pipes with air tight seals;
4. Polyethylene sheathed tie-down strands; and
5. Corrosion inhibiting compound within the strand sheathing.

The tie-downs use the same anchorage details and redundant corrosion protection system used on the stay cables. The service life of the tie-down system is further enhanced by the inclusion of a reference strand in each tie-down cable that can be removed and inspected without affecting the tie-down capacity.

The superstructures are restrained transversely at the towers and anchor piers by shear keys located at the bridge centrelines.

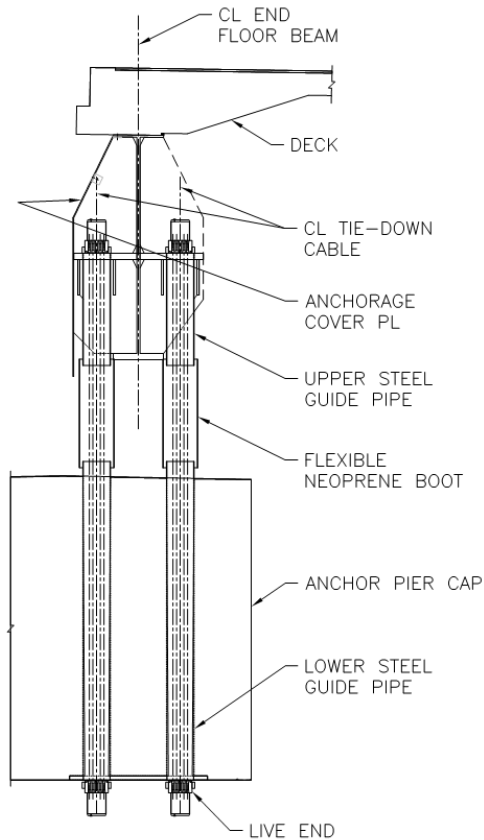

Figure 3: Section through anchor pier tie down.

Foundations

The anchor piers are supported on 24 – 6' (1.83 m) diameter steel pipe piles, with 1" (25 mm) wall thickness, driven to the top of bedrock or into the glacial till overlying the bedrock approximately 225' (68 m) below the underside of pile cap at the west anchor pier and 165' to 200' (50 m to 61 m) below the underside of pile cap at the east anchor pier. The piles are filled with reinforced concrete to a depth of 125' (38 m) below the pile cap. A plan view of the anchor pier foundation is shown in Figure 4.

The main towers are supported on 64 - 6' (1.83 m) diameter piles, with 1" (25 mm) wall thickness, driven to bedrock or into the glacial till overlying the bedrock, located 250' to 280' (76 m to 85 m) below the underside of pile cap at the west tower and 240' to 260' (73 m to 79 m) below the underside of pile cap at the east tower. The piles are filled with reinforced concrete to a depth of 140' (43 m) below the pile cap. A plan view of the tower foundation is shown in Figure 5.

The anchor pier and tower piles are fitted with a 2.5" (64 mm) thick reinforced tip over the bottom 10' (3 m) of the pile length to effectively seat the piles in the bearing stratum. The steel pipes are ASTM A572 Grade 50 (345 MPa). Each pile has a maximum factored geotechnical design compressive strength of 5,600 kips (24.9 MN).

The anchor pier and tower piles are reinforced with bundles of ASTM A615 Grade 75 (500 MPa) #18 (55M) bars with a maximum reinforcement ratio of 4.4%. The infill concrete has a minimum 28-day compressive strength of 5000 psi (34.5 MPa). The proportioning of the pile reinforcement is governed by the design lateral ship impact load of 9,000 kips (40.0 MN) at the anchor piers and 23,000 kips (102 MN) at the towers.

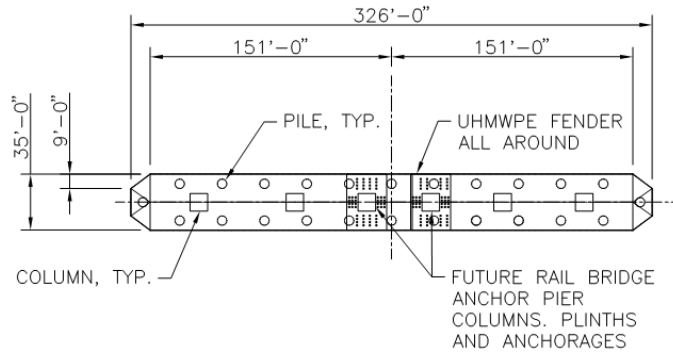

Figure 4: Plan view of anchor pier pile cap.

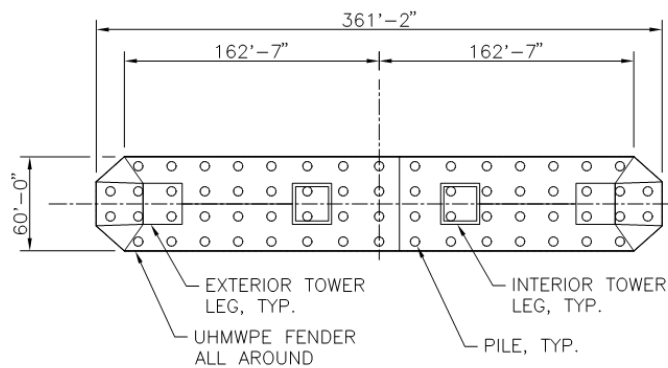

Figure 5: Plan view of tower pile cap.

Substructures

Pile Caps

The east and west bound anchor piers are supported on a single reinforced concrete pile cap that is 12' (3.66 m) thick and 326' (99.4 m) long and 35' (10.7 m) wide, as shown in Figure 4. A single pile cap is used to mobilize the lateral load capacity of all piles to resist the governing ship impact loads, even though this does not result in the most efficient pile layout for supporting vertical loads. The pile cap thickness, length and distance between the east and west bound piers result in the pile cap being relatively flexible. The effects of this flexibility on the distribution of loads to individual piles and the corresponding effects of the pile cap were considered in the design.

The east and west bound towers are supported on a single reinforced concrete pile cap that is 14' (4.27 m) thick and 361' (110.1 m) long and 60' (18.3 m) wide, as shown in Figure 5. Similar to the anchor piers, a single pile cap is used so as to mobilize the lateral load capacity of all piles to resist the governing ship impact loads and the effects of pile cap flexibility on pile and pile cap demands were significant and important considerations in the design.

The pile caps are constructed from concrete with a minimum 28-day compressive strength of 5,000 psi (34.5 MPa) and are reinforced with ASTM A615 Grade 75 (500 MPa) bars with #18 (55M) bars being used for the majority of horizontal reinforcement. The top surfaces of the pile caps are sloped away from the centreline at 2% to avoid ponding water.

The leading edges of the pile caps are shaped to reduce the effects of ice loading. The pile caps are faced around their entire perimeter with ultra-high molecular weight polyethylene (UHMWPE) sheeting to deflect and reduce damage due to vessel impact and ice abrasion.

Anchor Piers

The reinforced concrete anchor piers comprise reinforced two-column bents with 11' x 11' (3.36 m x 3.36 m) foot square columns and 12' (3.66 m) deep by 15' (4.58 m) wide cap beams as shown in Figure 6. The crown of roadway elevation is approximately 137' (41.8 m) above the top of pile cap. The anchor piers are constructed from concrete with a minimum 28-day compressive strength of 6,000 psi (41.4 MPa) and are reinforced with a combination of ASTM A706 Grade 60 (400 MPa) and ASTM A615 Grade 75 (500 MPa) bars. The ASTM A706 bars are used in the pier columns in potential plastic hinge regions.

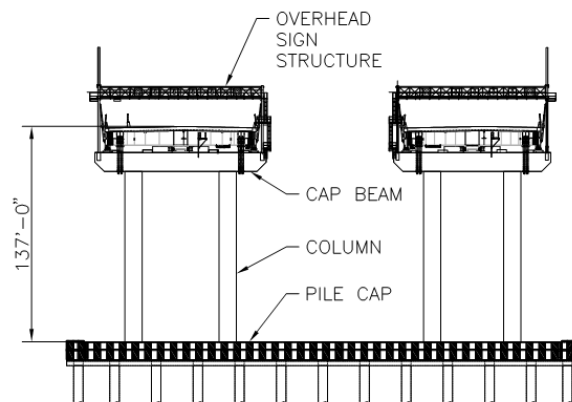

Figure 6: Elevation view of anchor piers.

Towers

The main towers comprise outward leaning legs that form a V-shape with a single cross beam below deck, as shown in Figure 7. The reinforced concrete tower legs vary in width from 25' (7.63 m) at the base to 15' (4.58 m) at the tower top and in depth from 26' (7.93 m) at the base to 17' (5.19 m) at the underside of cross beam, above which the depth is constant. The concrete cross beam is 28' (8.54 m) deep and 16.5' (5.03 m) wide and is post-tensioned by six 12-strand tendons per flange. The north tower legs of the west bound bridge and the south tower legs of the east bound bridge are solid to a height of 60' (18.3 m) above the pile cap to resist direct bow impacts from the larger ships transiting the crossing. The towers are constructed from concrete with a minimum 28-day compressive strength of 6,000 psi (41.4 MPa) and are reinforced with ASTM A615 Grade 75 (500 MPa) bars, except in potential plastic hinge regions, where ASTM A706 bars are used for improved ductility and more stringent control over yield and tensile strengths.

The outward tower leg slopes allow the inward leaning bending moments resulting from the eccentric stay-cable anchorages to be partially balanced by the tower leg weight. The omission of an above-deck cross beam, commonly used to resist these loads, reduces construction costs, shortens construction schedule and provides a clean above-deck appearance.

Structural steel stay-cable anchorage trays are cast into the upper tower legs and are spaced vertically at approximately 6' (1.8 m). The steel anchor trays resist the tensile splitting forces imposed on the upper tower section by opposing pairs of cable anchorages, transfer the vertical cable force component to the tower transverse walls via shear studs on the end plates and transfer any unbalanced horizontal cable force components that would result from the unlikely failure or controlled replacement of a stay-cable to the longitudinal tower wall via shear studs on the primary web plate. An isometric partial cut-out view of a typical anchorage tray is shown in Figure 8. The anchor trays are connected with stay-in-place forms to create a singular continuous steel anchorage unit. This allows the geometry of the full anchorage unit to be carefully established in well controlled shop conditions. The arrangement provides for excellent geometry control during tower construction by avoiding the need to set the geometry of each cable

anchorage individually. The stay-in-place forms are three-sided and open to the tower leg interior, providing access to the stay-cable anchorage below for cable stressing and future inspections. The stay-cable anchorage trays and stay-in-place forms are fabricated from ASTM A709 Grade 50W (345 MPa) steel. The stay cable anchorage trays are defined as fracture critical members.

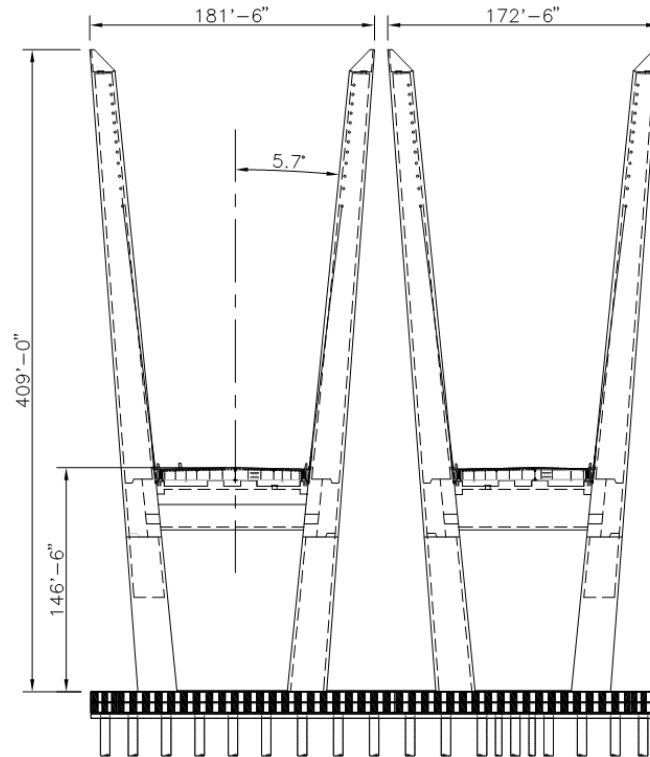

Figure 7: Elevation view of towers.

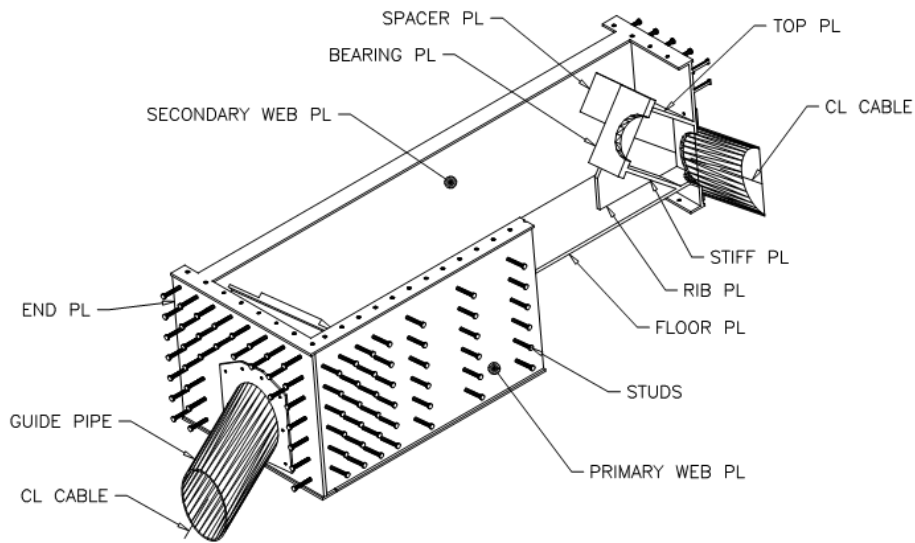

Figure 8: Isometric view of a typical stay-cable anchorage tray.

Superstructures

General

The main span superstructures comprise structural steel edge girders, a centrally placed longitudinal redundancy truss and transverse floorbeams spaced at 16' (4.88 m). The edge girders, redundancy truss and floorbeams act compositely with a reinforced and post-tensioned precast concrete deck. A typical west bound deck cross section is shown in Figure 9. The superstructure is supported by stay cables spaced at 48' (14.64 m), or every third floorbeam, along each edge girder. The stay cables are connected to the superstructure through anchorages external to the deck cross section. A nominal 1 inch thick polyester-polymer concrete overlay wearing surface is provided. The success of composite cable-stayed deck systems is based upon the repetitive prefabrication of simple modular bridge elements in controlled shop conditions, maximizing efficiency and quality. Careful detailing ensures fit of the components and ease of erection. The precast deck system effectively eliminates the need for formwork that would otherwise be required to construct the concrete deck. The system provides a reliable construction schedule and has been proven as economical throughout North America. The reduced mass and inherent flexibility of the composite deck system reduces dead and seismic loads, minimizing foundation demands, which is particularly important given the challenging subsurface conditions of the site, and is more economical than an orthotropic steel deck.

The omission of the above deck tower cross beam increases the torsional flexibility of the superstructure, reducing the vertical-to-torsional frequency ratio that is a general indication of aerodynamic performance. The aerodynamic performance is further affected by the use of 42" (1.06 m) tall concrete TL-5 traffic barriers along the deck edges, which result in a very blunt leading edge. Section model and full aeroelastic wind tunnel tests were completed by wind specialists Rowan Williams Davies and Irwin Inc. (RWDI) of Guelph, Canada to confirm the aerodynamic performance of the main span and the aerodynamic enhancements that were ultimately required. The section model testing showed that the unenhanced bridge deck had an insufficient flutter speed, was susceptible to vortex shedding-induced oscillations and that there was considerable aerodynamic interaction between the adjacent, but unconnected, bridge decks. Several aerodynamic enhancements were tested in the wind tunnel and it was determined that the aerodynamic instabilities were best mitigated by providing wind fairings along the outer edges of the two bridge decks and a below-deck baffle plate along both bridge centrelines. The wind fairing is a longitudinally stiffened steel plate structure supported by intermediate diaphragms at floorbeam locations. It comprises two segments, an approximately horizontal segment 6.5' (1.98 m) wide and leading edge segment approximately 5' (1.53 m) wide angled downwards at 40°. The baffle plates are longitudinally stiffened steel plates 9'-8" (2.95 m) deep spanning between floorbeams. These enhancements are provided over the central three quarters of the main span. The aeroelastic testing of the bridges, complete with aerodynamic enhancements, confirmed that the bridge would meet the aerodynamic performance requirements.

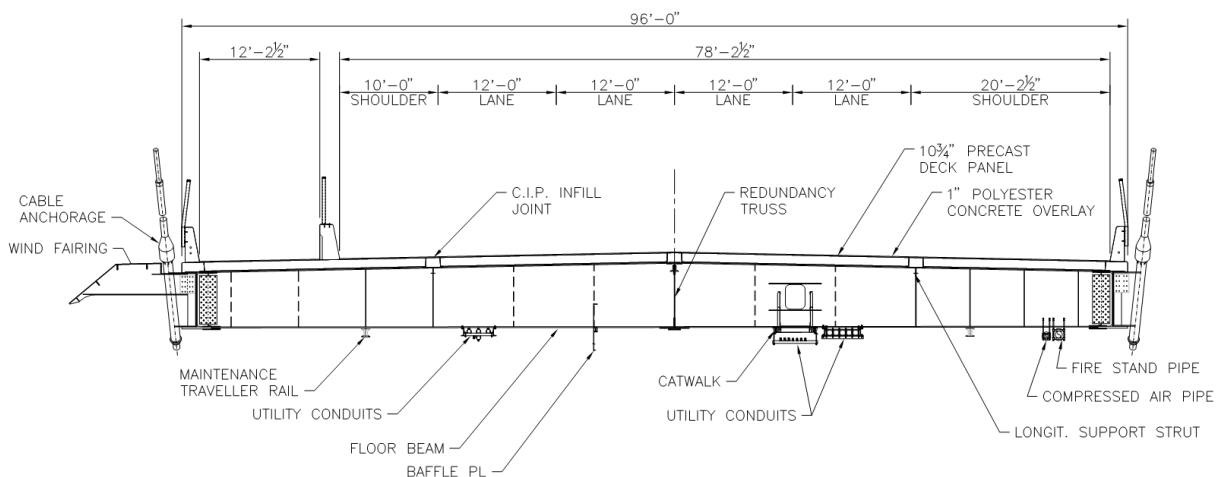

Figure 9: West bound deck cross section at stay-cable anchorages.

Edge Girders

The steel edge girder web depth is typically 5'-6" (1.68 m), but increases gradually to 11'-7" (3.53 m) over the 120' (36.6 m) adjacent to each anchor pier. The girder was kept relatively shallow to improve the aerodynamic performance of the deck section. The increase in depth is required to carry additional demands imposed by the anchor stays and to reduce the torsional moments on the anchor pier cap beams by lowering the elevation at which longitudinal shears are applied by the fixed bearings.

The edge girders are subjected to concurrent axial, shear and flexural stresses and the sequence of stress application to the steel section during construction is an important design parameter. As such, the provisions of AASHTO LRFD are not appropriate or sufficient for the verification of the edge girder design. Therefore, in addition to performing the relevant AASHTO LRFD design verifications, the edge girders have been verified in accordance with "Eurocode 3 Design of steel structures – Part 1-5: Plated structural elements," which more appropriately addresses the behaviour of steel panels subjected to combined of axial, shear and flexural stresses.

The girder top flange is a constant 28" (710 mm) wide and is 1.25" (31 mm) thick, except for the deck segment at the towers, for which it is 1.75" (44 mm) thick. The girder bottom flange is a constant 36" (914 mm) wide and varies in thickness from 1.75" to 4" (44 mm to 100 mm). The girder web varies in thickness from 13/16" to 1.5" (21 mm to 38 mm). The edge girders are fabricated from a combination of ASTM A709 Grade HPS 70W (480 MPa) and Grade 50W (345 MPa) steels.

Floorbeams

Floorbeams between cable anchorages are approximately 4'-8" (1.42 m) deep at their connection to the edge girders, and vary in depth across the bridge width to suit deck cross falls. Floorbeams at cable anchorages are 5'-6" (1.68 m) at their connection to the edge girders. The floorbeams at and between cable anchorages are provided with a web cut-out near the bridge centreline to allow continuous access along the underdeck catwalk. The edge girders and floorbeams are made composite with the precast concrete deck panels with cast-in-place infill joints. The floorbeams at the cable anchorages have full moment connections to the edge girders to transmit force effects from the eccentric cable connections. The floorbeams between cable anchorages have simple web-only connections to the edge girders.

A special floorbeam at the tower transmits transverse loads on the superstructure to the towers through a steel shear key bolted to the bottom flange at the bridge centreline. The tower floorbeam has the same depth as the floorbeams at cable anchorages.

A special floorbeam at the anchor pier acts as an end-diaphragm, transmitting transverse loads on the superstructure to the anchor piers through a steel shear key bolted to the bottom flange at the bridge centreline. It also transmits the significant tie-down forces into the cap beam. Because of their importance in the primary structural load path for the bridge, the anchor pier floorbeams are defined as fracture critical members.

All floorbeams are fabricated from ASTM A709 Grade 50W (345 MPa) steel.

Concrete Deck

The reinforced and post-tensioned concrete deck has an initial thickness 10.75" (273 mm), which includes a 0.75" (19 mm) allowance for milling of the polyester polymer concrete wearing surface three times during the service life of the bridge. The concrete deck is inherently in compression as a result of the inclined stay cables. However, near the anchor piers and midspan, where dead load compressive stresses are low, supplemental pre-compression is provided by 4-strand longitudinal post-tensioning tendons. The pre-compression of the deck minimizes cracking, which enhances the service life of the deck system. The deck post-tensioning comprises 0.6" (15.2 mm) diameter weldless low-relaxation

strands conforming to the requirements of ASTM A416, Grade 270 (1860 MPa). The precast deck panels have a minimum 56-day compressive strength of 9,700 psi (66.9 MPa) and the cast-in-place concrete infill joints have a 28-day compressive strength of 8,000 psi (55.2 MPa). The deck is reinforced with a combination of ASTM A615 Grade 60 and 75 (400 MPa and 500 MPa) bars. The precast deck panels are aged a minimum of 180 days prior to installation to reduce long-term creep and shrinkage effects.

Stay Cables

The stay cables are connected the superstructure by steel anchorages bolted to the outside face of the edge girders, as shown in Figure 10. The anchorages comprise a steel anchor pipe, stem plate, stem mounting plate and top and bottom flange plates. The anchorages are a critical structural element, particularly in terms of the required fabrication tolerances, as misalignment of the anchor pipes could result in unwanted stay bending and the cable strands bearing directly on the pipes, rather than having space to accommodate the expected cable movements.

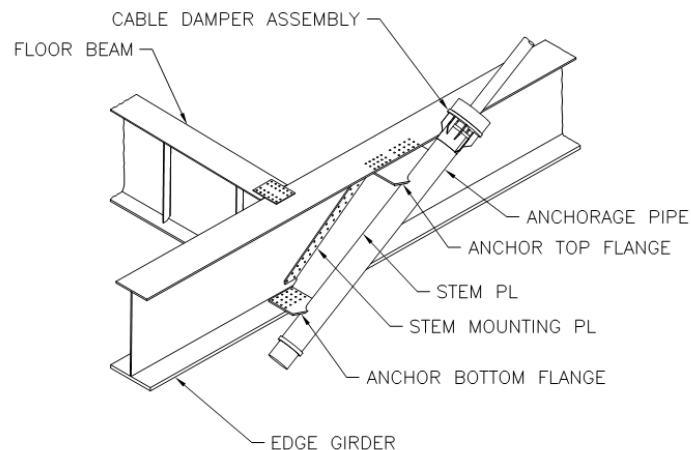

Figure 10: Isometric view of a typical stay cable anchorage.

The anchorage pipes are fabricated from API 5L Grade X52 (360 MPa) steel, varying in outer diameter from 16" to 22" (406 mm to 559 mm). The other components of the anchorage bracket are fabricated from ASTM A709 Grade 50W (345 MPa) steel.

The stay cables comprise individually polyethylene sheathed, parallel 7-wire strands with an ultimate tensile strength of 270 ksi (1860 MPa). Each individual 7-wire strand is filled with a corrosion inhibiting blocking compound. The bundle of strands is contained in UV-resistant co-extruded HDPE pipes with helical ribs to prevent rain-wind induced vibrations. Potential vortex shedding, rain-wind and ice galloping cable vibrations are mitigated by the provision of dampers within the stay pipes near the lower cable anchorages. Friction dampers will be used to provide damping values between 0.33% and 1.0% of critical. Damping values will be confirmed by in-situ testing of a selection of the dampers on the completed bridge. The stay cables are sloped away from the road surface, mitigating potential problems with accumulated ice falling onto vehicles below. The stay cables are designed to be stressed from the upper anchorage located in the tower leg. The number of strands per cable varies from 23 to 98.

Redundancy

Similar to the importance placed on service life design, the provision of redundancy in the New NY Bridge was a strong guiding principle. The bridge includes several features that address operational and structural redundancy.

Operational redundancy refers to the flexibility available to the bridge operator to adjust how traffic is conveyed across the bridge. Operational redundancy is provided first by separate east and west bound

bridges. Both bridges are designed with sufficient width and capacity to carry eight lanes of traffic – four east bound and four west bound, which makes it possible to shut down one of the bridges without a long term or significant decrease bridge availability. The additional deck width provided to carry two-way traffic on each bridge results in wide inner and outer shoulders being available while both bridges are in service. The west bound bridge provides shoulders 10' and 20' (3.05 m and 6.10 m) wide and the east bound bridge provides shoulders 10' and 25' (3.05 m and 7.63 m) wide. The wide shoulders allow the traffic lanes to be shifted on the deck to mitigate the effects of a traffic incident and to possibly accommodate a dedicated bus rapid transit lane in the future.

Structural redundancy refers to the ability of the bridge to sustain localized damage/failure without it leading to progressive collapse. The edge girders and floorbeams were shown not to be fracture critical by extensive non-linear time-history analysis of several potential failure cases, including a fractured edge girder, fractured floorbeam and loss of cables. Cable-stayed bridges are inherently redundant as the superstructure is supported by closely spaced cables and floorbeams, such that the loss of any one can usually be sustained. The redundancy of the New NY Bridge and its ability to sustain the localized fracture of these components is enhanced by the provision of the longitudinal redundancy truss placed near the bridge centreline. This third longitudinal element in the deck cross section prevents substantial displacements of the deck and floorbeams adjacent to a fractured member such that the deck remains stable. Although not provided specifically to improve the longitudinal distribution of live loads to multiple floorbeams, this is an added benefit that offsets the additional material required for the truss.

Future Commuter Rail Bridge

As part of the design development, provision had to be made for the future addition of a commuter rail bridge on the Crossing. The means of doing this were not prescribed, but the foundations constructed as part of the current design-build contract were required to carry the future rail bridge without retrofit, strengthening or future “in-water” work. The contract defined the design loading for the rail bridge as:

1. Two Cooper E60 locomotives or corresponding alternative 4-axle load with a Cooper E60 trailing load 1,000' (305 m) long on one track and
2. Two Cooper E60 locomotives or corresponding alternative 4-axle load with a Cooper E30 trailing load (14 cars; 85' (25.9 m) long each) on the other track.

This section describes the conceptual design developed for the future rail bridge and the modifications that would have to be made to the road bridge to accommodate it.

Articulation

The articulation of the proposed rail bridge is the same as that provided for the road bridges except for the vertical restraint at the towers. An effectively rigid vertical support at the towers with a very stiff superstructure and relatively flexible stay cables results in unmanageable hogging moment demands. However, with a single plane of stay cables, it is still necessary to provide torsional support at the towers. Therefore, the rail bridge is supported on hydraulic cylinders on both sides of the deck cross section that are coupled, such torsional deformations of the superstructure are restrained and vertical deformations can occur freely. This is done by having the hydraulic fluid reservoir on the lower end of the device on one side of the superstructure connected to the reservoir on the upper end of the device on the other side of the superstructure.

Towers

In addition to being structurally efficient and aesthetically pleasing, the inclined road bridge tower legs permit the efficient future addition of a stay-cable anchorage unit between the tops of the two inner tower legs and a cross beam below deck to create an A-frame structure to support a cable-stayed rail bridge placed between the two road bridges, as shown in Figure 11. The structural efficiency of the A-frame minimizes the extent of structure that must be added to carry the future rail loading. The A-Frame created

by connecting the tower legs results in the interior legs seeing reduced transverse bending moments (moments about the bridge longitudinal axis), but increased axial forces and longitudinal moments due to additional dead and live load.

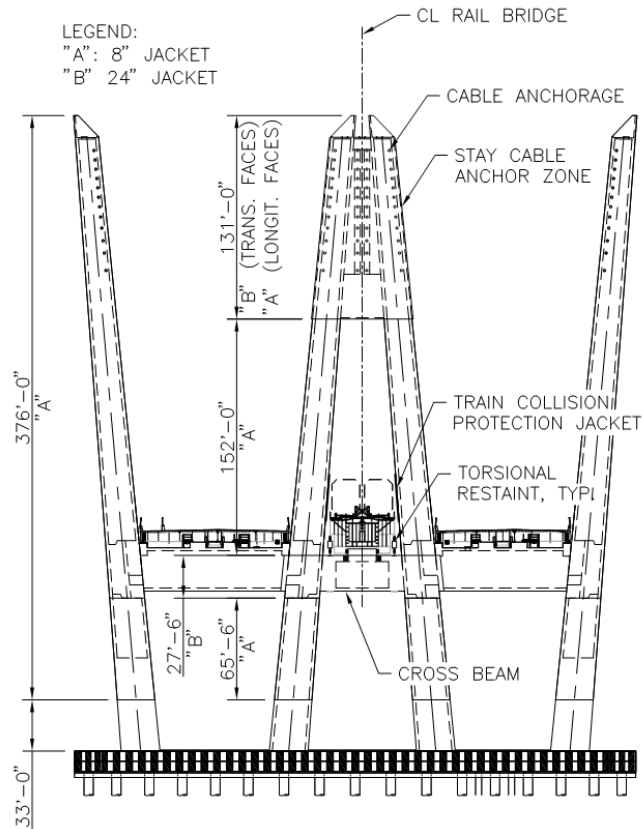

Figure 11: Towers after the addition of the rail bridge.

The additional tower demands applied by the rail bridge require the towers to be strengthened and modified, as described below:

- The axial and longitudinal flexural strength and stiffness of the tower legs are increased where necessary by thickening each of the transverse walls by 8" (203 mm). Concrete jackets are attached to the tower leg walls with drill and bond anchors. The thickening is reinforced longitudinally and transversely.
- The new stay cable anchorage zone at the tower top comprises transverse and longitudinal concrete walls that frame into the tower leg strengthening described above, however, in this region of the tower the strengthening thickness is increased to 24" (610 mm) (transverse wall of interior legs only). The transverse concrete walls are post-tensioned across the full width of the upper tower legs, through the tower leg strengthening and new cable anchorage zone to transfer the vertical component of the stay cable forces into the strengthened tower legs. Steel stay cable anchor trays similar to those used on the road bridges are used. Sufficient space is provided between anchor boxes in the vertical and horizontal directions for access. The cross section through the stay cable anchor zone in Figure 12 shows the location of the rail bridge cable anchorages relative to those of the road bridge and the strengthening and transverse post-tensioning required to support the rail bridge.

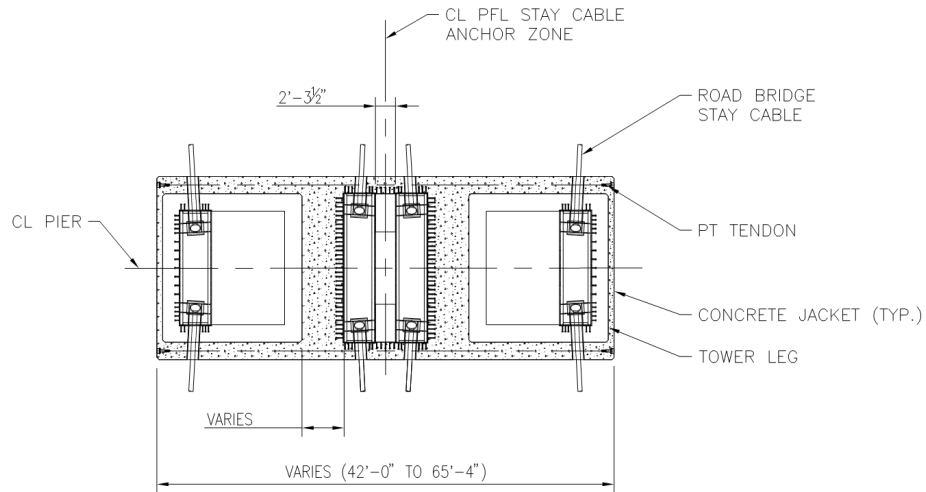

Figure 12: Cross section through rail bridge stay anchor zone.

- The new cross beam at deck level carries the local demands applied by the rail bridge articulation devices and the shear and bending demands resulting from the change in global behaviour of the tower that results from the connection of the two road bridge towers. The cross beam connects to the transverse and inner longitudinal faces of the interior tower legs as in the anchorage zone, with a similar strengthening thickness of 24" (610 mm) (interior legs only). The cross beam is post-tensioned over its full length. The elevation of the rail bridge cross beam in Figure 13 shows the support arrangement for the rail bridge at the tower and the post-tensioning required to make the new cross beam act together with the road bridge towers.

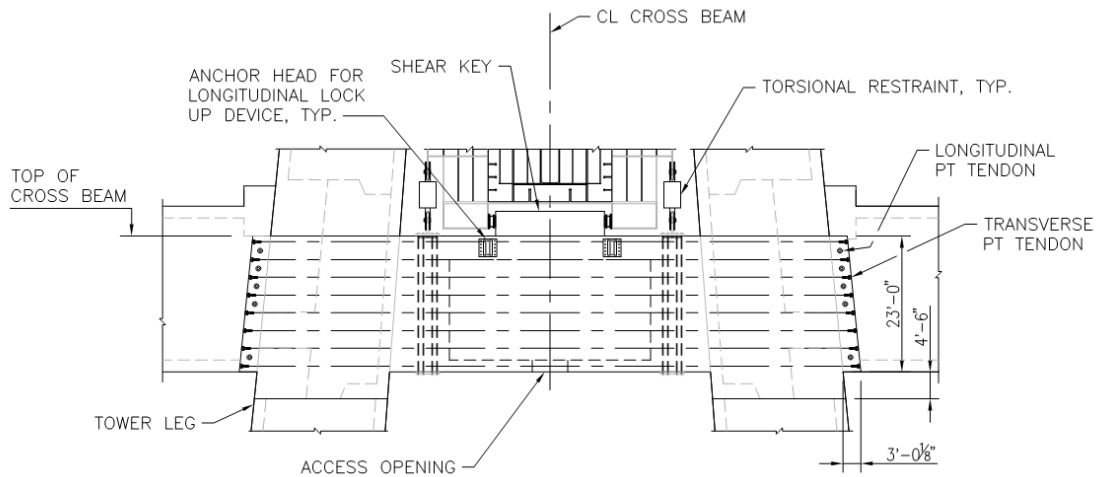

Figure 13: Elevation of rail bridge cross beam.

Anchor Piers

The rail bridge anchor piers comprise two reinforced concrete columns and a cap beam. They are supported on the road bridge anchor pier pile caps, but are otherwise independent from the road bridge anchor piers. This results in slightly larger demands in the anchor pier columns than if the road and rail bridge cap beams were connected, but it reduces demands on the cap beams and reduces longitudinal reactions between decks and substructure elements. The rail bridge anchor pier columns are connected to a pair of plinths, which in turn are connected to the existing pile cap by means of post-tensioned high-

strength steel bars. The bars are drilled and bonded into the existing pile cap before stressing. The pile cap will be cast with survey pins attached to the top reinforcement layers to indicate where the future high-strength steel bars should be placed to avoid conflicts.

Because the road and rail bridges are connected at the tower tops, the rail loading increases longitudinal demands on the road bridge anchor pier legs, even though the road and rail anchor piers are not joined. The road bridge anchor pier columns must be strengthened with 8" (203 mm) thick concrete jackets on the transverse faces, similar to the strengthening applied to the tower legs.

Superstructure

The rail bridge superstructure accommodates two tracks, each having a clearance envelope 18'-0" (5.5 m) wide and 23'-0" (7.0 m) tall. The composite deck comprises a longitudinally and transversely stiffened steel box section with a 10" (254 mm) thick reinforced concrete deck slab. The deck slab comprises precast panels that are made composite with the steel box by cast-in-place infill strips. The trains are assumed to be powered by an electrified third rail and the rails connected to a cast in place concrete plinth via direct fixation fasteners. The deck cross section is shown in Figure 14.

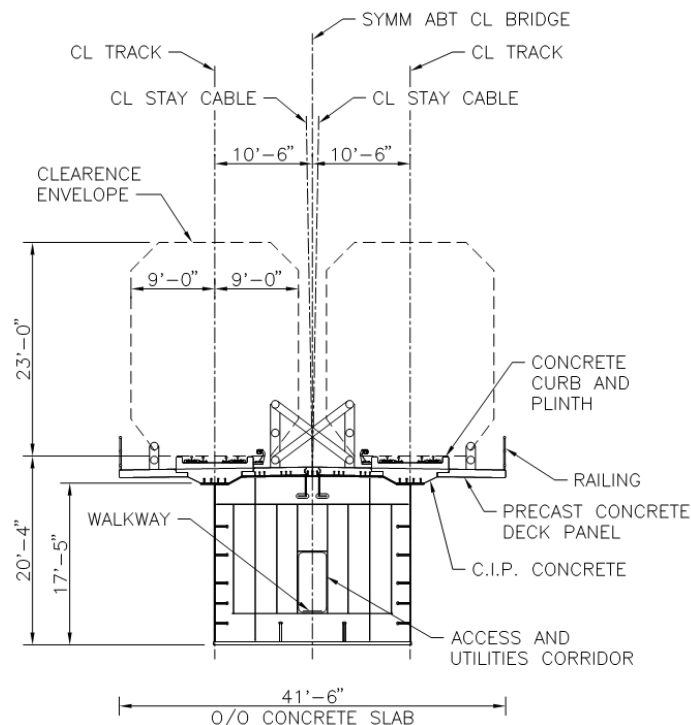

Figure 14: Rail bridge superstructure cross section.

Rail bridge performance is more sensitive than is road bridge performance is to differential rotations and displacements, and to dynamic interaction between the bridge, the train and other load effects. AREMA does not provide sufficient criteria to fully verify the performance of a long span rail bridge and so additional project specific criteria were developed to support the design of the main span rail bridge. Superstructure deflection and runability performance criteria were developed based on Eurocode, International Union of Railways (UIC) and German Institute of Standardization (DIN) criteria, and experience with other long span rail bridges. Criteria that supplement or replace AREMA criteria were developed for:

1. Maximum vertical deflection and gradients.
2. Maximum angular rotation in the vertical plane.
3. Maximum angular rotation in the horizontal plane.

4. Maximum transverse slope of the tracks.
5. Maximum deck twist.
6. Runability - derailment/wheel climbing.
7. Runability - overturning risk.

A steel box with a depth of approximately 17.5' (5.34 m) and a width of 21' (6.41 m) is required to meet the design criteria. The steel box was proportioned considering a single cross section with 1" (25 mm) thick webs and a 4" (100 mm) thick bottom flange. Further optimization of the cross section is likely possible. The superstructure is supported every 24' (7.32 m) by a central single plane of prefabricated parallel wire stay cables with ultimate wire strength of 240 ksi (1650 MPa) and up to 499 - 0.275" (7 mm) diameter wires per cable. The stay spacing on the rail bridge is half of that used on the road bridges to mitigate the increase in cable areas beyond industry norms. Parallel wire cables are specified for the bridge because they are more compact, allowing for more manageable anchorage sizes, and have better fatigue performance than parallel strand cables, which is particularly important for rail bridges with heavy and repetitive live loading.

Summary

The New NY (Tappan Zee) Bridge main span comprises parallel east and west bound cable-stayed bridges with 1,200' (366 m) main spans and 515' (157 m) side spans. The main span comprises composite steel and concrete decks, parallel strand stay cables, iconic V-shaped reinforced concrete towers, reinforced concrete anchor piers and pile caps, and reinforced concrete-filled steel pipe pile foundations. The main span design included the conceptual design of a future commuter rail cable-stayed bridge to be placed between the road bridges. Recognizing the importance of the investment in the new bridge, the main spans are designed with appropriate consideration of service life (durability, access for inspection and maintenance and in-service structural health monitoring), aerodynamic performance, the imposed loading, structural behaviour and constructability and the ability to add rail transit in the future.

Acknowledgements

The authors gratefully acknowledge the contributions of their partners on the New NY Bridge project:

New York State Thruway Authority – Bridge Owner
Tappan Zee Constructors, LLC – Design Builder
HDR Engineering, Inc. – Lead Designer