

Calgary's Traveller Information System

Michael Gray, P.Eng, City of Calgary, Traffic Engineering Division (Presenter)
Yeatland Wong, P.Eng, City of Calgary, Transportation

Paper prepared for presentation at the
Strategic Road Safety Action Plans for Canadian Jurisdictions Session
of the 2013 Conference of the Transportation Association of Canada
Winnipeg, Manitoba



ABSTRACT

The Advanced Traveller Information System (ATIS) is a web-based technology which provides the public critical information on incidents, detours, road closures general road conditions and travel times. ATIS helps motorists make informed decisions to improve their commute, reduce the environmental impact of driving and lessen driver frustration.

As the primary source for traffic information in Calgary, ATIS makes it possible to communicate real-time information about Calgary's roadways through a variety of methods, including website updates, Smartphone access, subscription services, Dynamic Message Signs (DMS) and Traffic Advisory Radio updates. Additionally, static images from Calgary traffic cameras are fed to the ATIS website for viewing by the public using standard web browsers. News media can access this information to distribute it to the public via radio and television. Future access to traffic information is anticipated through Smartphone applications, additional websites and Global Positioning System (GPS) system providers by way of an open data feed.

The City of Calgary's Roads Traffic Engineering division and corporate website development team, Webwave, worked together to implement a new traveller information system in preparation for the launch of a new Calgary.ca website. Starting work in early 2011, the intent of this project was to replace the existing Condition Acquisition and Reporting System (CARS) system with a modern ATIS system.

Completed in November 2012, the ATIS proprietary software was created completely in-house by City of Calgary resources. In addition, a Bluetooth Travel Time Display system was developed to display actual travel times via DMS, and eventually, on the ATIS website.

INTRODUCTION

ATIS Vision Statement

The City of Calgary's vision statement regarding ATIS was the "to be the definitive source of traveller information for citizens related to mobility".

To accomplish this, the Traffic Engineering division endeavoured to create a web presence for traveller information which citizens could access to obtain information about the transportation corridors in Calgary.

The goal of ATIS was to replace the existing CARS system with a new, modern system that could improve travel times along critical routes, with improved access to traveller information about Calgary's roadways, including detours and traffic incidents.

This project was designed to take advantage of newer technologies, such as Really Simple Syndication (RSS), Geographic Information System (GIS) mapping engines and Bluetooth travel time sensors.

A revamped Calgary.ca website was launched in August 2011, using a Google search function as a critical part of its homepage. At the same time, an updated version of the City's ATIS site was created, available at calgary.ca/trafficinfo. The new ATIS system had some limitations on the new Calgary.ca website, and solution was required to be re-written to provide a more solid, extendable platform to allow the Traffic Engineering division to expand the traffic and road information to include the following features (Figure 1):

1. Availability of transportation layers on Calgary.ca, including the newly created "snow route parking bans" and other layers such as bus stops, Light Rail Transit (LRT) stations, etc.
2. Long term data storage through GIS, rather than the existing mechanism of storing data in Microsoft SharePoint and technical issues including hard limits of lists and performance slow downs.
3. Creation of automated situation reports through Systems, Applications and Products in Data Processing (SAP) business objects.
4. Achieve internal efficiencies for staff by automating work flow (Hansen detours automation).
5. Development of open data feeds for customers through RSS and Keyhole Mark-up Language (KML) for software developers and data sharing between organizations internal and external (Alberta Transportation, internal business units like Geospatial Emergency Management team, Alberta Motor Association).
6. Creation of a support model for ATIS.
7. Creation of a Bluetooth travel time system for DMS display and eventual display on Calgary.ca (Figure 2).

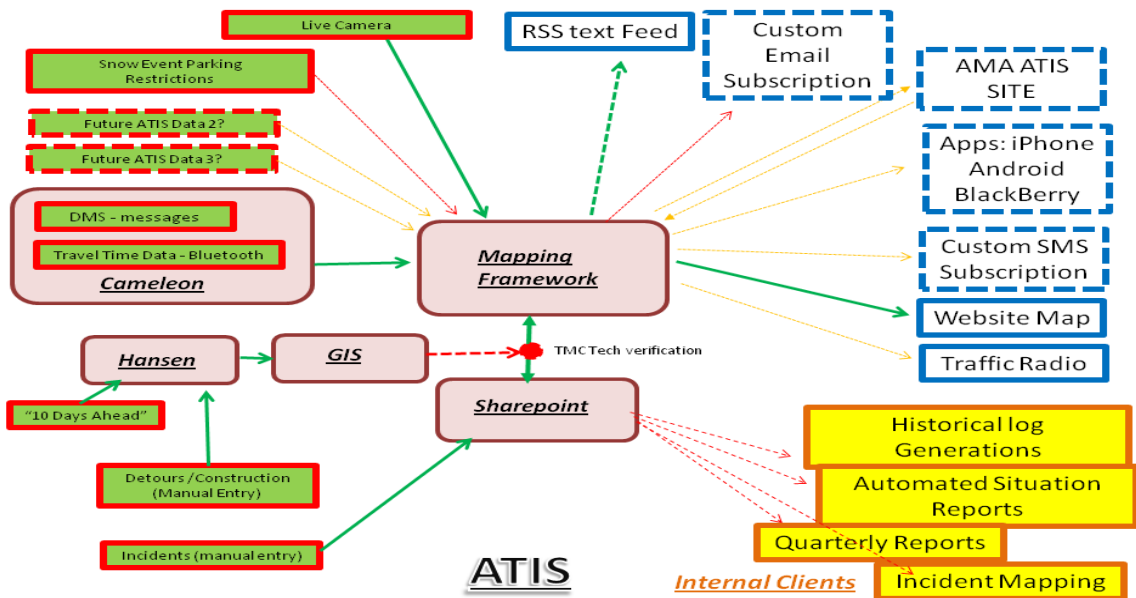

Figure 1: High Level ATIS System

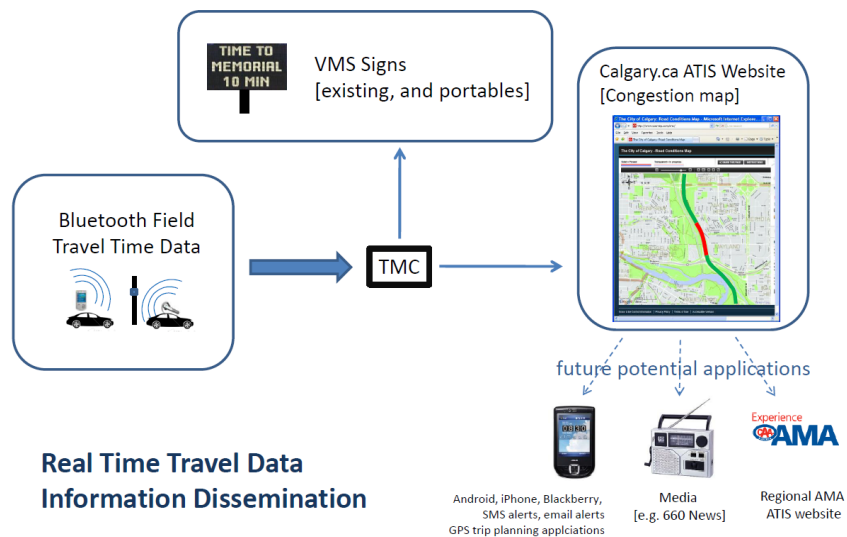

Figure 2: Bluetooth System Uses

ATIS SOFTWARE DEVELOPMENT

Transportation Layers, Interactive Maps and RSS

The following are key components of the Calgary ATIS system:

1. Traffic Report Page: Summary of all active incidents and planned construction and detours in Calgary.
2. Interactive Map: GIS map with selectable transportation layers.
3. SAP business objects for simplified reporting.
4. Open data feeds for subscription purposes and software development (RSS and KML).

The ATIS project was completed in two phases. Phase 1 was done by City of Calgary's team Webwave to take advantage of the corporate wide revamp of Calgary.ca, while phase 2 was completed by a separate internal IT software development team.

Phase 1

With the Calgary.ca website being revamped, the Traffic Engineering division identified the opportunity to move away from the old ATIS system to become more tightly integrated into Calgary.ca.

Phase 1 consisted of storing all ATIS data (incidents and detours) into Microsoft SharePoint, the use of SharePoint as a data entry interface and the development of a dynamic mapping service.

The dynamic mapping service was created primarily to facilitate Calgary's "Snow Route Parking Ban". The parking ban GIS layer needed to be displayed on the ATIS interactive map and the dynamic mapping service pulled that information off an ArcGIS file and updated the mapping framework (Figure 3).

Another aspect was to develop an interactive map to include other transportation layers that would be useful to the travelling public, such as LRT, bus routes and parking zones. In addition to the standard Calgary.ca/trafficinfo site, RSS was made available to subscribers. RSS requires the subscriber to use a standard RSS reader (either through internet browser or third party application) to view traffic incidents and detours.

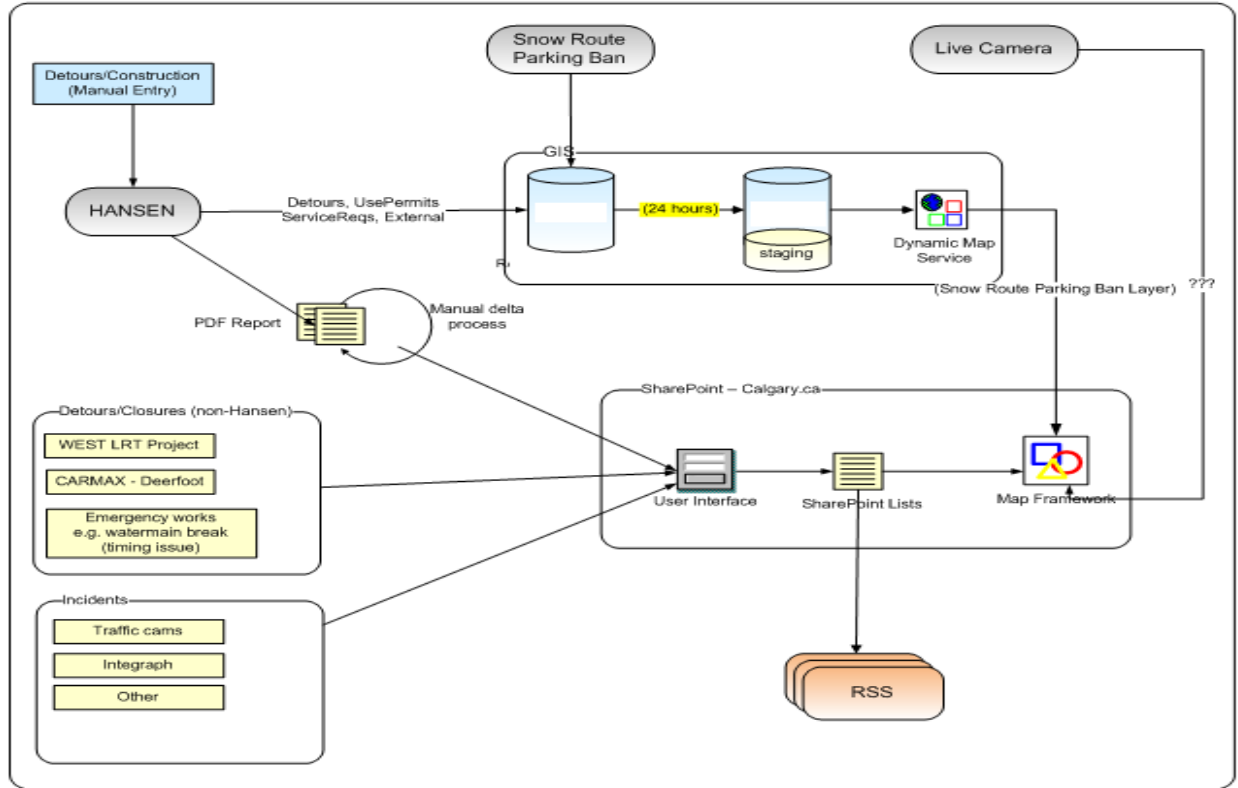

Figure 3: ATIS Phase 1

Phase 2

Phase 2 of the project (Figure 4) was set up to address five concerns:

- SharePoint list sizes and performance degradation.
- The need to produce situation reports (SAP business objects) for supervisors and managers.
- Manual duplicate entry of detours and construction information.
- Create an open data feed.
- A sustainable support model.

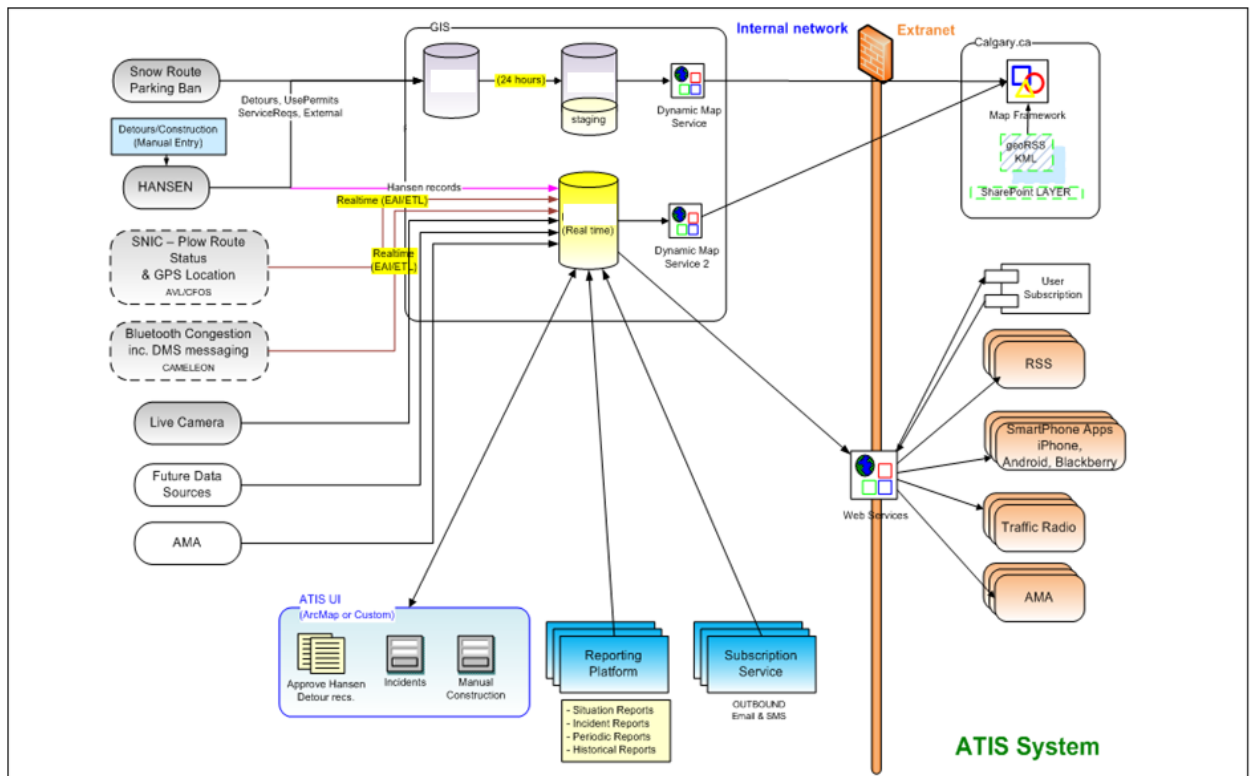

Figure 4 ATIS Phase 2

SharePoint List Sizes and Performance Degradation

SharePoint was used in phase 1 as a data entry and data storage device. Two SharePoint lists were developed, Map Incident Location List and Map Construction List. It was discovered during the project that SharePoint list sizes begin to see performance issues when the number of records exceeds 5000 rows of data. In 2010-11 alone, ATIS records were already exceeding that limit (Table 1).

List	No. of records 2010-2011
Incidents	5,696
Construction/Detours	4,800

Table 1: SharePoint List Sizes

Additionally, SharePoint list sizes cannot readily join to additional data sources for querying purposes. This would make future expansion difficult to include services such as a notification through SMS or email. To support a notification service, the existing system would need to perform a query against the SharePoint list and the user's preferences. To address these issues, it was decided to create a custom user interface for ATIS and use GIS as a backend for storing ATIS records.

SAP Business Objects

A custom ATIS user interface (Figure 5) was designed to move away from SharePoint as a data entry mechanism. The data storage was also moved from SharePoint to a GIS Spatial Database Engine (SDE). By moving to GIS, automation of reports was enabled through SAP business objects. Business objects (web intelligence) is a system that allows Structured Query Language (SQL) queries to be sent to GIS data directly and setup regular schedules for reports.

The City of Calgary has found that "30 minute situation reports" is a useful tool for managers to constantly stay informed on citywide incidents. Although most of this information is on Calgary.ca, the situation report provides managers with additional information that the public typically wouldn't see, for instance if there is an incident which requires traffic signal timing changes or DMS activation.

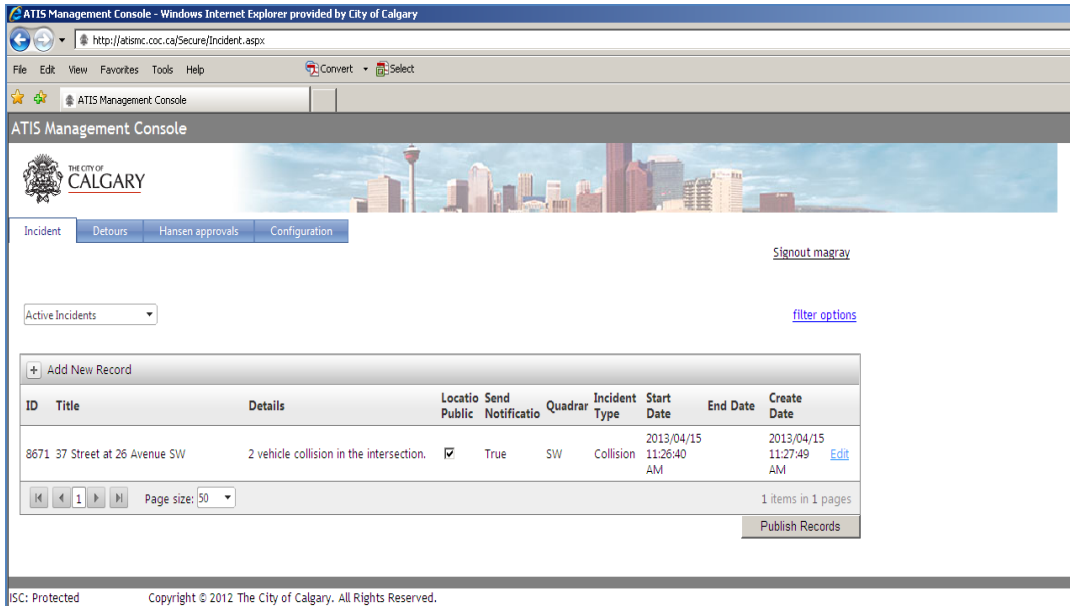

Figure 5 ATIS UI

Hansen Automation

Phase 2 also addressed the manual traffic detour ATIS process.

Road closures in The City of Calgary are handled internally by Roads Traffic Engineering, using Hansen, a tool to track detour closures. Hansen is a work management system software used to create work orders for road closures. In the past, ATIS technicians would find each work order in Hansen and manually enter the data into the ATIS website, a cumbersome process that required duplicate work. The custom ATIS User Interface (UI) was re-designed in phase 2 to retrieve data from Hansen, saving ATIS technicians from having to enter the data manually (Figure 6). Although the process is automated, it still requires technicians to review the work order to confirm accuracy, and to publish it on the web.

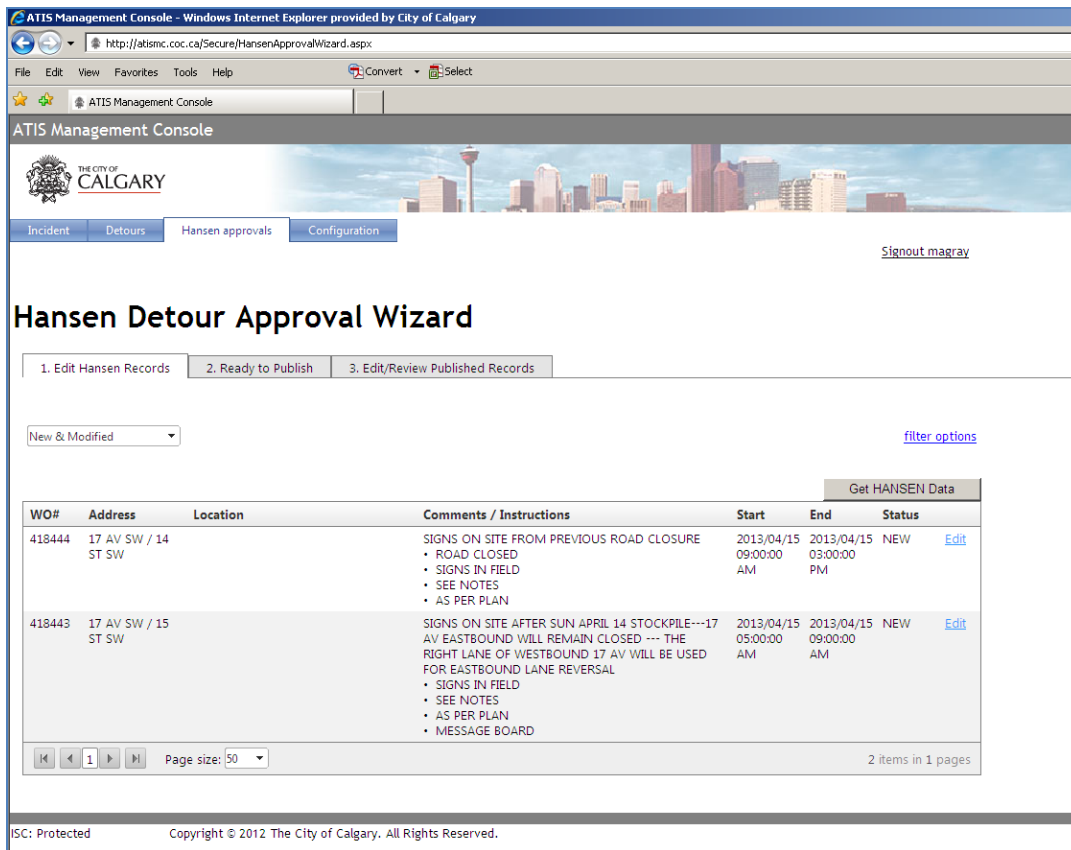

Figure 6: Detour Automation

Open Data Feeds

The final piece in software development work was the creation of an open data feed for third parties. While RSS was already available as a subscription service, it was decided to also use KML data to encourage software developers to write custom ATIS applications. The benefit to having KML data is that it is geo-coded with point coordinates of incidents and detours. KML is designed specifically for use with Google platforms.

Traffic Engineering has had multiple requests to share their data with individuals and companies (internal and external). It was decided to use a KML data feed to provide this service to internal and external stakeholders (Figure 4). While available now, the KML data feed will eventually be rolled out to Calgary City Online for complete public consumption.

The free data feed is a high load/high volume application with updates every five minutes, therefore it is critical to ensure City servers can handle the increased load. The key idea behind the development of the data feed is to leverage “crowd sourcing” and to further disseminate data. In addition, maintenance costs for future application development and updates are avoided. The final ATIS product is shown in Figure 7.

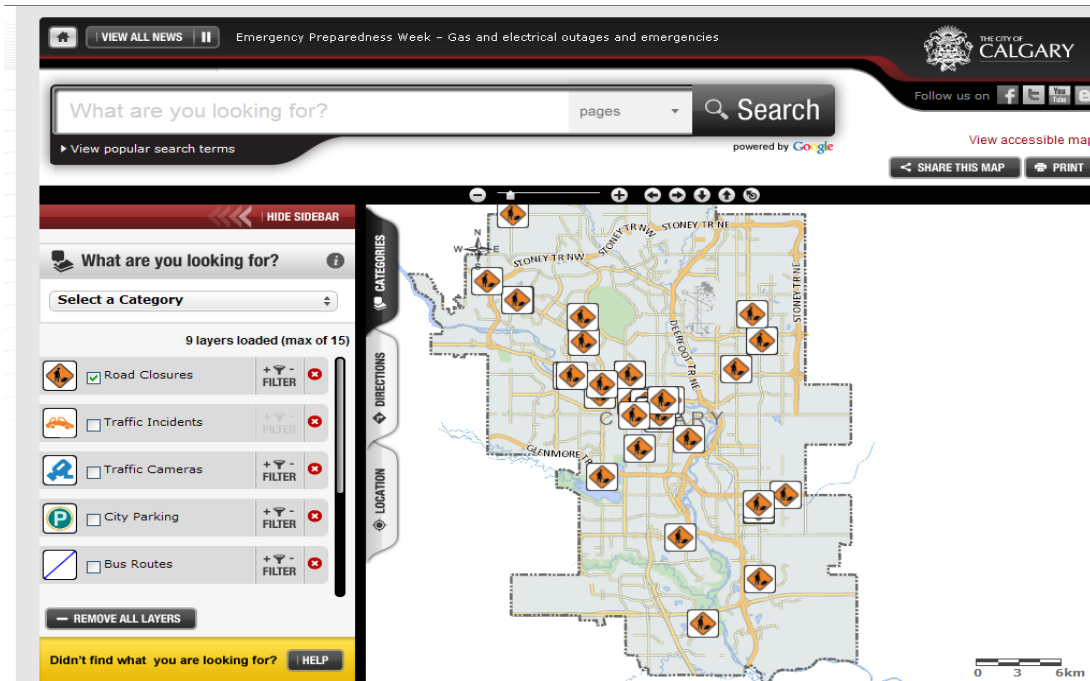

Figure 7: Calgary.ca/trafficinfo

Support Model

After the system was built and cutover to the production environment, the next step to this project was to determine the support model. From a data entry perspective, the ATIS system is updated by two ATIS technicians Mon-Fri 5:30 am-7 pm; however, an important consideration is the long term sustainability of the system in place. The Calgary ATIS system is completely supported internally by The City IT department and follows the model in Figure 8. The model relies on the ATIS technicians to do the initial investigation to determine which component is working incorrectly.

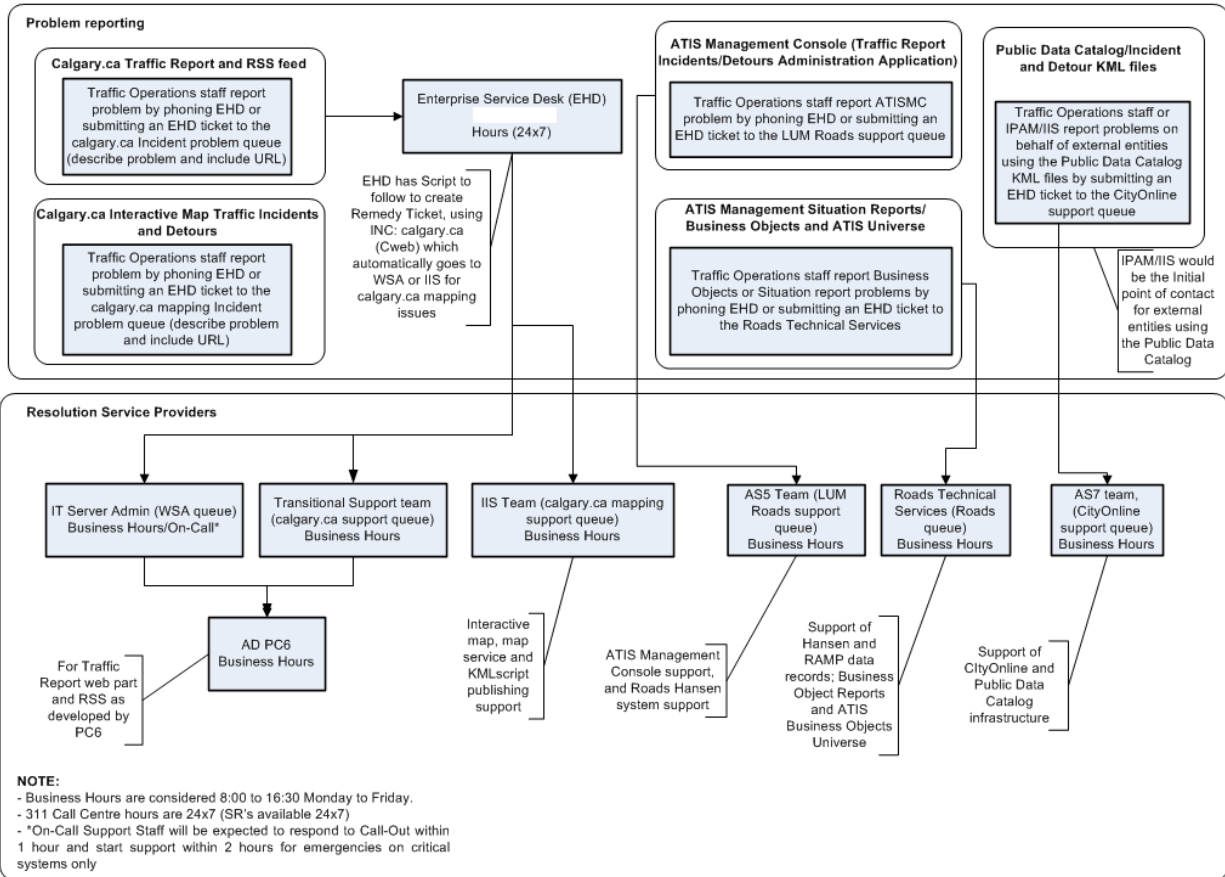

Figure 8: ATIS Support Model

The main components to the ATIS system are:

- Calgary.ca Traffic Report Page and RSS feed.
- Calgary.ca interactive map.
- The ATIS UI.
- ATIS SAP business objects.
- KML data feed.

After determining the cause of ATIS working incorrectly, the ATIS technician can submit a ticket to the IT department for resolution.

BLUETOOTH SYSTEM

Travel Time System Selection

Alongside the software development of the ATIS website, a travel time estimation system was being designed. The decision to use Bluetooth technology for travel time estimation was based on a one-week pilot project that The City of Calgary implemented in November 2010. The pilot project was consisted of 12 Bluetooth sensors and 12 DMS deployed along Deerfoot Trail, and was very well received by the public (Figure 9).

Despite the success of the project it was decided that to offer this service to Calgarians on an ongoing basis, the travel times needed to be an automated process with the ability for operators to override controls if necessary. This was added as an in-scope item for this project.



Figure 9 Calgary Sun Article

A competitive Request for Proposal (RFP) process was used to award the contract for the supply of Bluetooth sensors and travel time estimation software. Software development on Calgary.ca was completed in-house by City IT software developers, and all field installation and configuration was done in-house by City Traffic Engineering staff.

Bluetooth Travel Time System Operation

The ATIS Bluetooth travel time system consists of seven permanent DMS and 26 Bluetooth sensors along Deerfoot Trail, Crowchild Trail and Glenmore Trail. The Bluetooth devices are roadside mounted detection equipment, capable of monitoring Bluetooth Medium Access Control (MAC) addresses from Bluetooth enabled devices in vehicles driving past the detection equipment (figure 10). MAC addresses and detection times are recorded and transmitted to a central server located in the Traffic Management Centre (TMC). The server processes this information and calculates a travel time, which is then re-transmitted to the DMS in the field. This process is automated and involves storing the travel time data in Extensible Mark-up Language (XML) format, that file being read by the DMS software (Cameleon 360 Surveillance software), then the DMS software sends an update to the DMS in the field. 360 software monitors the Bluetooth sensor's travel times but also monitors the quality. When a sensor is offline, the quality of the sensor is degraded and the software does not post travel times. Eventually this XML file will be used to post travel times directly onto the ATIS website. Figure 10 illustrates how the Bluetooth system operates.

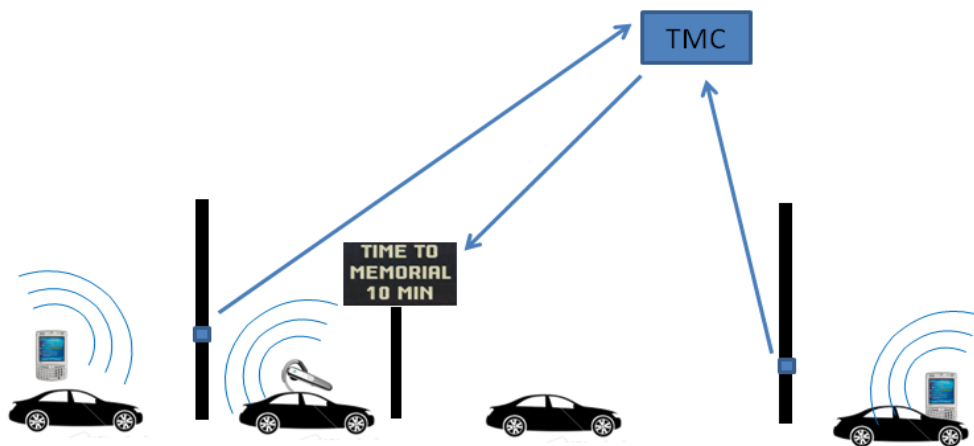

Figure 10 Bluetooth Block Diagram

The DMS software is on a priority system. Since the travel time system is automated, the travel times are posted on a low priority informational basis (Figure 11). If a traffic incident with a high priority develops, the travel times can be overridden with incident information. When the incident clears, the operator clears the information on the message board and the travel times will resume.



Figure 11 Calgary's Bluetooth System

To measure the accuracy of the system, a time trial was completed during the pilot phase. The test vehicle used the floating car technique, and the geologger data was compared to the Bluetooth data. The results are summarized in Figure 12.

Decreased accuracy may occur during times of heavy congestion due to fewer data points from slower moving traffic. The travel times on the DMS indicate the average travel time to reach a destination, but the travel time will have changed by the time a driver who sees that sign reaches the destination. As wait times fluctuate, this "error" becomes more noticeable.

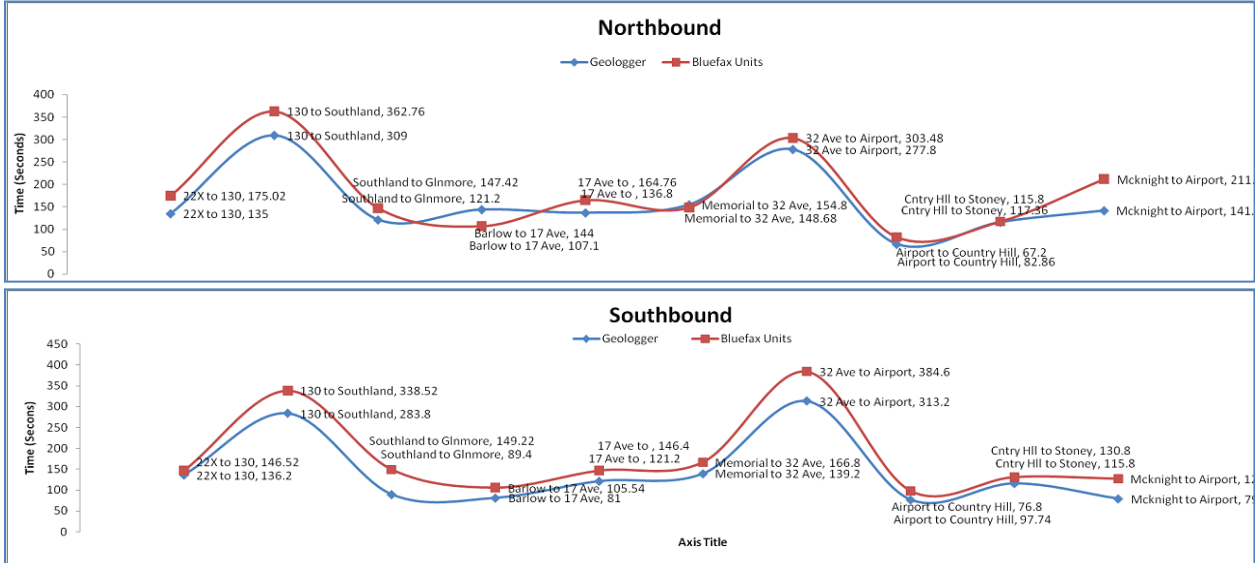

Figure 12 Floating Car vs. Bluetooth data

Privacy Concerns

The information recorded by the Bluetooth sensors is not considered to be personally identifying information. MAC ID's are assigned at the Bluetooth electronic chip manufacturers, and are not tracked through the sales chain. The MAC addresses are not associated to any particular person, user account, and vehicle or through any centralized database. Users concerned with privacy can select set-up options in their device so that the device will not be detectable.

To proceed with this project, The City of Calgary completed a Privacy Impact Assessment (PIA) to comply with Calgary's Freedom of Information and Privacy (FOIP) protocols. This PIA was approved by The City's FOIP office in 2012.

PROJECT COSTS

This project was a joint venture between The City of Calgary, Alberta Transportation and Transport Canada. Transport Canada provided a matching grant of up to \$250,000 and Alberta Transportation provided use of all DMS located on Deerfoot Trail for travel time display. The City of Calgary provided all project management, engineering and field installation. The total cost of the system was \$526,443, including all software development costs for calgary.ca/trafficinfo, procurement of sensors and wireless equipment, and field installation and construction. Project costs are summarized in Table 2.

														SCHEDULE C-Rev. 1 PROJECT # 2010-03		
CITY OF CALGARY - TRAVELLER INFORMATION SYSTEM																
BUDGET FORECAST																
<i>(Fiscal year begins on April 1st and ends on March 31st)</i>																
COSTS	Fiscal year 2011-12						Fiscal year 2012-13						Total		Total	
	3rd quarter Oct - Dec		4th quarter Jan - Mar		1st quarter Apr - June		2nd quarter July - Sept		3rd Quarter Oct - Dec		4th quarter Jan - Mar		Cash	Inkind	Contribution	
	Cash	Inkind	Cash	Inkind	Cash	Inkind	Cash	Inkind	Cash	Inkind	Cash	Inkind	Cash	Inkind		
Salaries and benefits														0	0	0
Consultants														0	0	0
Material, software	55,796		17,343		162,919		24,370		4,775					265,203	0	265,203
Equipment			21,750		111,966									133,716	0	133,716
Communication costs														0	0	0
Other operating costs (installation costs)					4,442		58,649		64,433					127,525	0	127,525
Total costs	55,796	0	39,093	0	279,327	0	83,018	0	69,209	0	0	0	526,443	0	526,443	
CONTRIBUTIONS¹																
City of Calgary (50%)	27,898		19,546		139,663		41,509		47,826					276,443	0	276,443
Transport Canada (50%)	27,898		19,546		139,663		41,509		21,383					250,000	0	250,000
Total contributions	55,796	0	39,093	0	279,327	0	83,018	0	69,209	0	0	0	526,443	0	526,443	

¹ subject to reprofiling at the sole discretion of the Minister of Transport

Table 2: ATIS System Costs

LESSONS LEARNED

- There were issues with Microsoft SharePoint as a user interface. Specifically, it was found that this interface experiences performance degradation after a certain number of rows (5000) has been reached. After this was discovered, a customized interface was developed and storage was done through the City of Calgary corporate SDE.
- Integration into a corporate SDE environment is required. This allows for flexibility when sharing data throughout the corporation. A good example of this is ATIS data being shared with emergency management to allow them to better manage emergencies because their road information is more accurate and is integrated into their own system.
- Open data concepts: Through the 311 system, requests are received for data from third parties who are willing to write applications on the City's behalf. This should be a consideration when developing a traveller information system.
- Reporting capabilities: The ability to share information in an organized manner is important. It was chosen to use SAP business objects for this project. Business objects allows the sharing of data by means of SQL queries, but also allows those customized reports on a schedule with internal or external stakeholders. This has proved to be extremely valuable for supervisors, managers and directors who are not necessarily inside the operations centre but with customized reports are always "plugged into" what is happening. The most popular of these reports in Calgary is "30 min situation reports".
- Bluetooth systems: The means of communicating with the sensors is cellular High Speed Packet Access (HSPA) modems (called Bluetree) from Telus. Since the modems are data only, they were "falling asleep" after being inactive for a few minutes and required a hard reboot in the field. To resolve this issue, two workarounds were implemented:
 - 1) A script was setup to poll each modem every minute.
 - 2) Timing circuits were connected to each modem that reboots the modem every 30 minutes. The combination of these two workarounds has resolved the issues and should be a consideration when purchasing Bluetooth sensors. Where possible fibre optics or dedicated radio (i.e. 900MHz, 2.4 GHz, 5.8 GHz) should be used for connection into an organization's Local Area Network (LAN). This project did not allow these options since the LAN was not in proximity and was cost prohibitive.
- Bluetooth systems: PIA. This is something which can take time to get through a city's FOIP office, therefore enough lead time needs to be given for evaluation of this.

CITIZEN FEEDBACK

This project was well received by the public and media, as shown by the comments captured by the 311 system in Table 3 below.

Comments
<i>"Pleased with the City's use of the signs on Deerfoot"</i>
<i>"Caller thinks the timing signs on Deerfoot Trail are a wonderful idea and has appreciated them this week."</i>
<i>"Info signs on Deerfoot are very helpful - they are accurate too"</i>
<i>"loves the travel time info boards on deerfoot"</i>
<i>"Caller loves the new deerfoot information system - says it seems the traffic calmer and it is fairly accurate"</i>
<i>"Caller wanted to have the program permanent"</i>
<i>"Found it very useful. Caller would like to keep the service."</i>
<i>"Caller found the bluefax devices on deerfoot trail very helpful. Caller wishes there was more. Caller would like to see them installed in the industrial park."</i>
<i>"Caller wanted to say the signage on deerfoot is appreciated and appeases drivers to know how long for travel. caller would like to see the signage continue during rush hour and difficult weather"</i>
<i>"Caller wanted to call in and give positive feedback about the Travel Time Information System. He thinks it's great, and hopes to see it continue, really helped out his drive today."</i>

Table 3 Citizen Comments

CONCLUSIONS

A key metric for project success was ATIS website metrics. In 2011 the total number of visitors to the Calgary Traffic Report Page (www.calgary.ca/trafficinfo) was 23,687. For 2012, the total number of hits was 119,601. The traffic camera portion of the website in 2011 received 15,079 visitors and in 2012 was 76,560.

Individual views of cameras is not currently monitored, instead this is the number of people who visited the main traffic camera page. These numbers show the increased level of interest in the ATIS site since the site was redesigned.

Anecdotally, observations indicate the Bluetooth travel time system is accurate during offpeak and peak times and also during adverse conditions like collisions and weather. This is consistent with the results of the geollogger comparison to the Bluetooth data. The travel time system was also well received by the public as evidenced from feedback through the 311 system.

Going forward, the ATIS system will be constantly evolving. One of ROADS departmental goals is to better inform the public. ATIS is one of the major ways ROADS disseminates information, therefore improvements to the system will constantly be sought. One such project is to make the KML data feed available to the public. The intent is to release this information for free to the public through the public data catalogue available at Calgary CityOnline. This incident and detour data is updated every five minutes (Mon-Fri 5:30am to 7pm). If this project is successful, the City will be the “data source” and will rely on the public to build applications.